

# Card reader

PART #: SSH-Z051B-A00

## KEY FEATURES

- 13.30Lx11.18Wx1.35H mm
- With detect switch
- Hinge type
- Contact position acc. To GSM

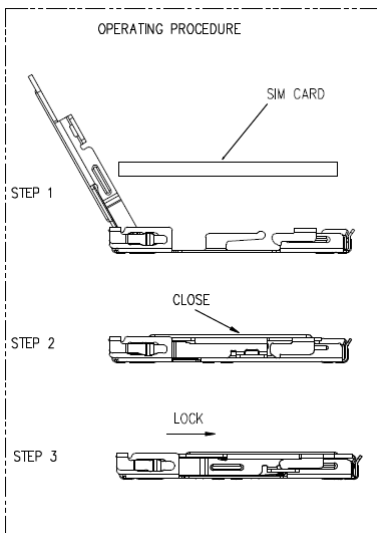
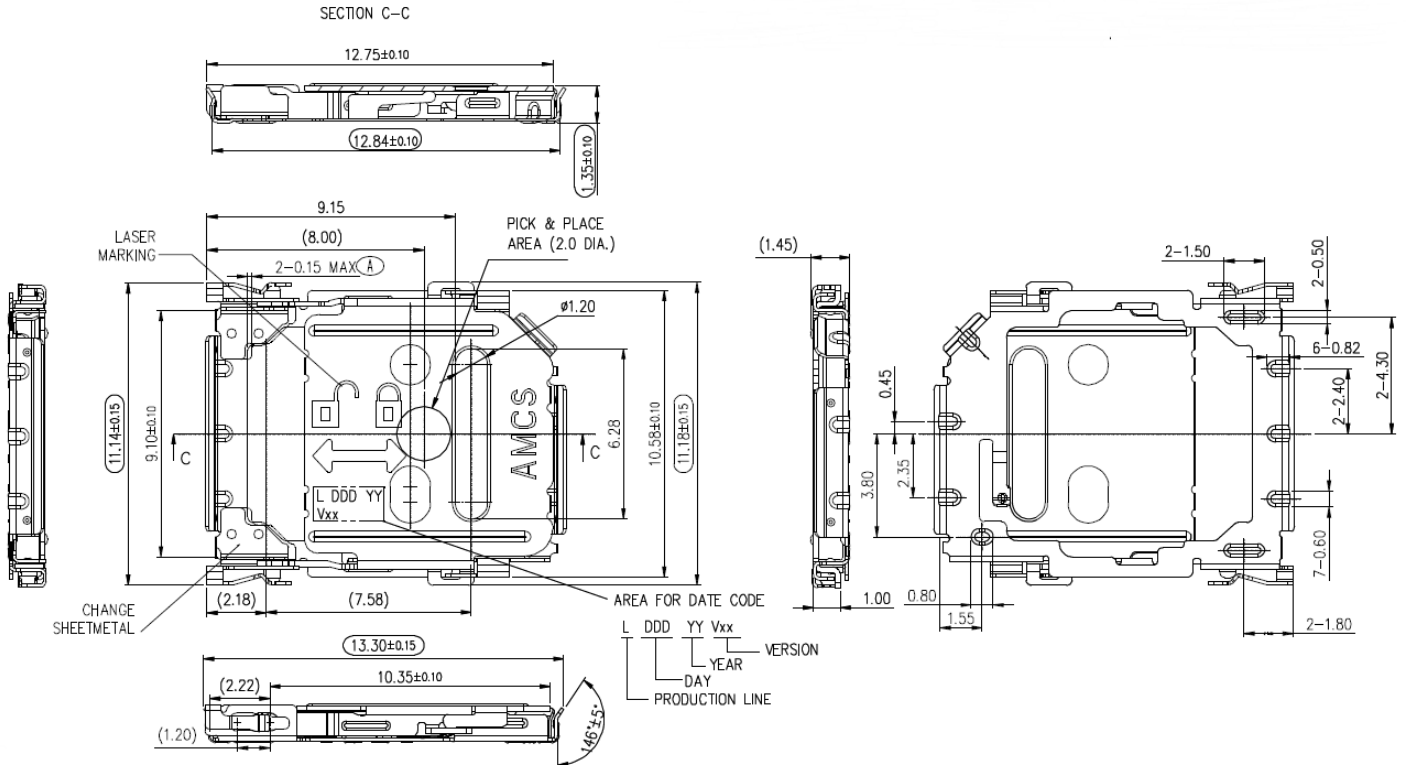
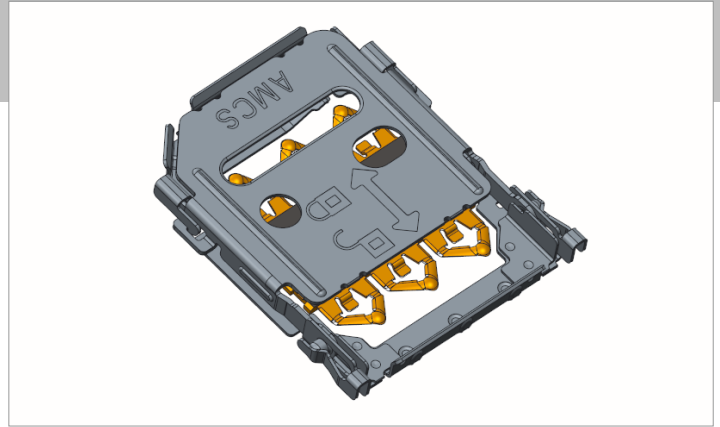

### Recommend PCB Layout

Recommend tolerance: ±0.05  
Recommend Stencil Thickness: 0.10

